

DETAIL	QTY	PARTNO	DESCRIPTION
DB	01	HOUSING	SEE CHART
⊕ DC	01	DR SHAFT	SEE CHART
BD	01	0004-BD2	SPIDER
BE	01	0004-BE	CLAMP COLLAR
* AK	01	9602-AK	BUSHING
⊕ 01	01	0004-01	WOODRUFF KEY
* 02	01	0004-02	UPPER DRIVE SHAFT BEARING
⊕ 03	01	G1D	SPIRAL MITER GEAR DRIVE
* 04	01	0004-04	.500" DIA. EXPANSION PLUG
* 05	01	0004-05	FRONT SPINDLE BEARING
⊕ 06	01	G1S	SPIRAL MITER GEAR DRIVEN
07	02	1D1L-07	#6-32 X .25 BHCS
08	01	0004-08	1/16 X 1/2 ROLL PIN
* 09	01	0004-09	LOWER DRIVE SHAFT BEARING
10	04	1D1L-10	10-32 X .500 SHCS
11	01	1M-HA-11	SIZE 1 EL COLLET SCREW

SPINDLE CHART			
DETAIL	QTY	PARTNO	DESCRIPTION
⊕ AG	01	9602-AG	SPINDLE TAPERLOCK
⊕ AGW	01	9602-AGW	SPINDLE WELDON
⊕ EL	01	STEL	SPINDLE ELTOOL COLLET

\* Recommended repair parts.  
⊕ Perishable items.

HOUSING DRIVESHAFT CHART			
LENGTH	PARTNO DB	PARTNO DC	
1.500"	0004-DB15	0004-DC15	
3.000"	0004-DB30	0004-DC30	
4.500"	0004-DB45	0004-DC45	
6.000"	0004-DB60	0004-DC60	

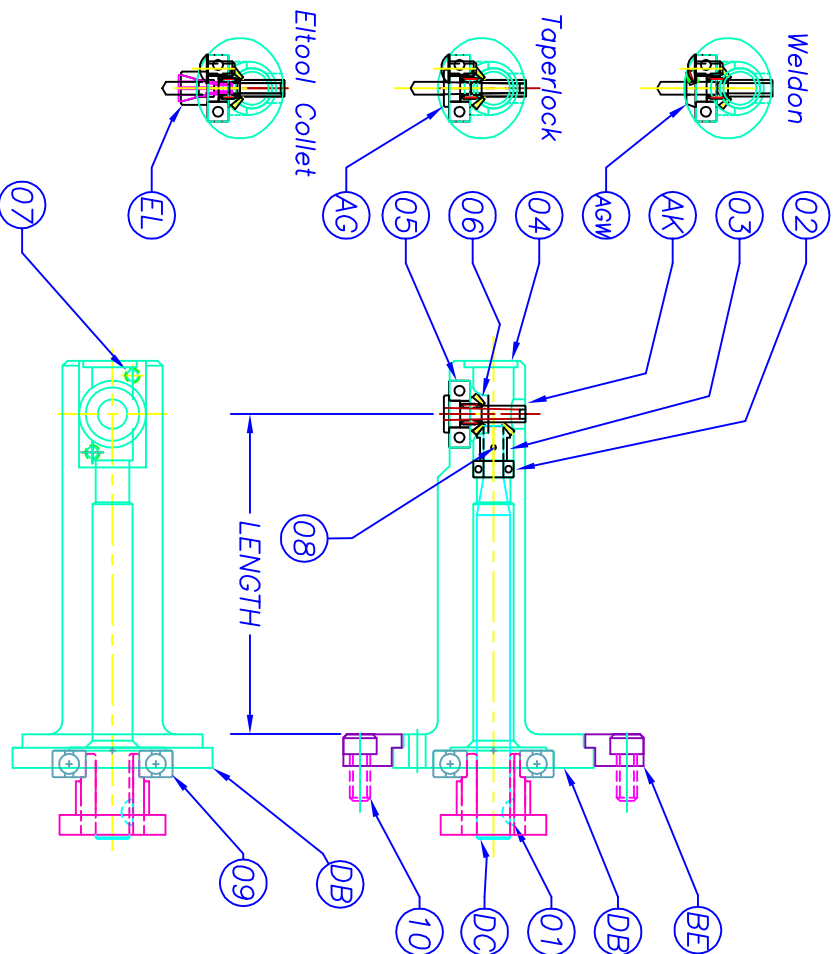

TOLERANCES (UNLESS OTHERWISE NOTED)	
DECIMAL	±
3 PLACES	±
2 PLACES	±
1 PLACE	±
FRACTIONAL	±
ANGULAR	±

REVISIONS	
NO.	DATE BY

PART NAME		Size 1D	
DRAWN BY		JCY	
MATERIAL		SCALE	
CUSTOMER		DATE	
		1/01	
DRAWING NO.		1D-HA	